

Type TU Heavy Duty Tip-Up Bin

The type TU Heavy Duty Tip-Up Bin has been manufactured from 3mm plate and designed with a low profile to allow versatility in confined spaces. The pouring lip and smooth formed edges make the bin ideal for all food industry applications. The release mechanism is activated by the Forklift operator pulling the pull chord from the driver's seat. The custom built shock absorber prevents impact forces being transmitted to the Forklift during emptying.

All type TU bins have a Safe Working Load of 1000kg and range in sizes from 0.5 – 1.5 cubic metre capacities. These bins are available in either enamel painted over primed steel or H.D. Galvanised finish.

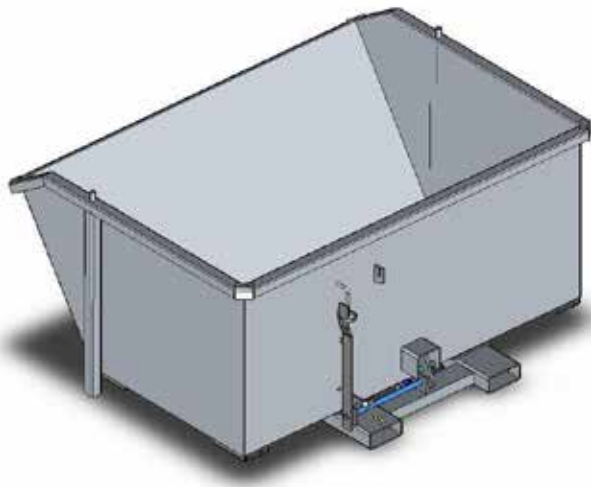

(Type TU18 standard model shown)
Refer 'TU_WL_Sales' Product Specification sheet for Wheels & Crane Lug options.

SPECIFICATIONS:

- Pocket size 165 x 65mm
- Pocket Centres – 635mm (TU6 – 405mm)
- Safe Working Load 1000kg
- Unit Weight – refer Table
- Volume Capacity – refer Table
- HCG 800mm
- VCG 400mm
- Crane Lugs, Wheels & Lid Optional
- Drain Valve & Strainer Optional
- Hydraulic Option available

