

Type SROB Sideways Roll Over Bin

The type SROB Sideways Roll Over Bin has been designed to tip in either direction. Side bearings prevent the bin being dislodged during tipping as is common with the roll over style bins. Fork Pockets are provided for end or sideways lifting and tipping. This bin is ideally suited to the food industry.

These bins are available in either enamel painted or Galvanised finish. Stainless Steel is also available on request. Ø150 front & rear swivel Wheels are supplied standard.

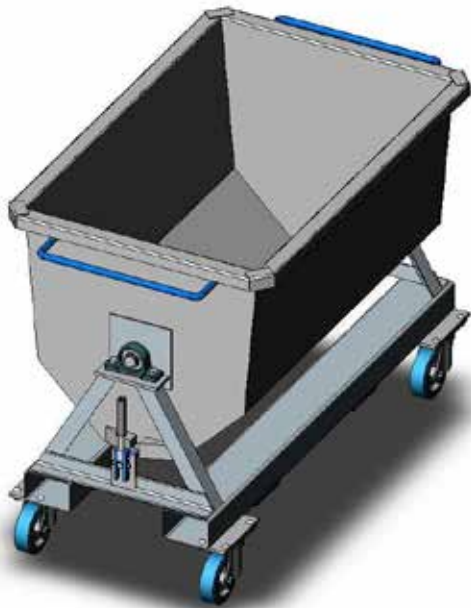

(Type SROB 12 shown)

SPECIFICATIONS:

- Safe Working Load 600kg
- Unit Weight – refer Table
- Volume Capacity – refer Table
- Pocket size 140 x 60mm
- End Pocket Centres – 450mm
- Side Pocket Centres – 600mm
- Crane Lugs Optional
- Drain Valve & Strainer Optional

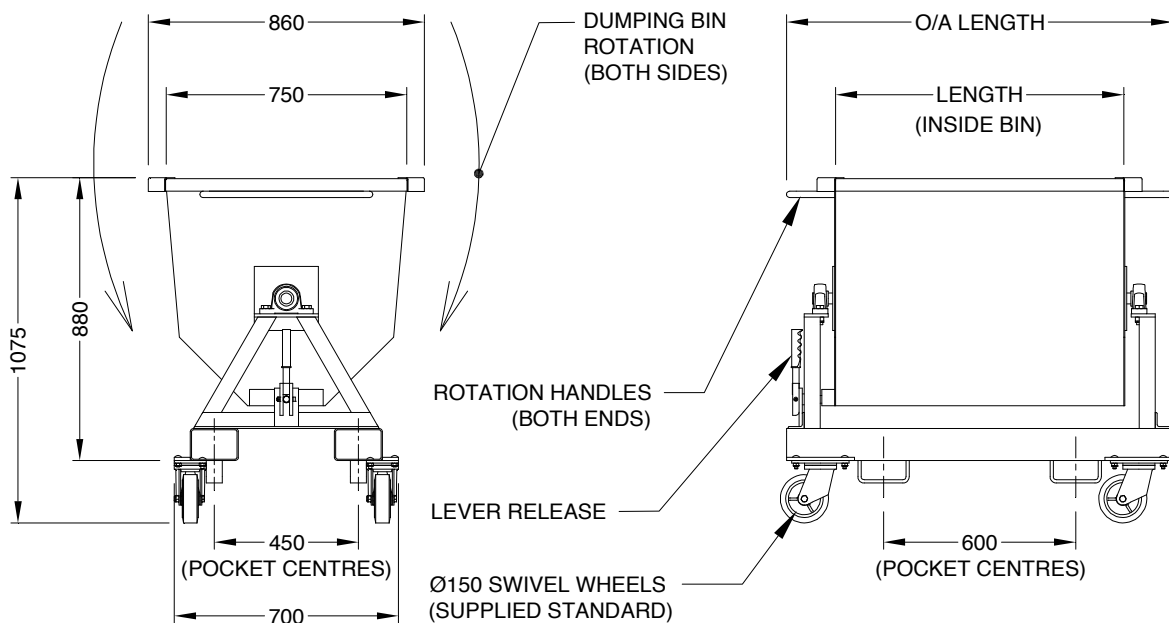

BIN TYPE	CAPACITY	'LENGTH'	'O/A LENGTH'	*UNIT WEIGHT
SROB-9	400 litres	900mm	1200mm	150kg
SROB-12	550 litres	1200mm	1500mm	170kg

* NOTE: 'Unit Weight' includes Weight of WHEELS.