

## Type NTU Heavy Duty Tip-Up Bin

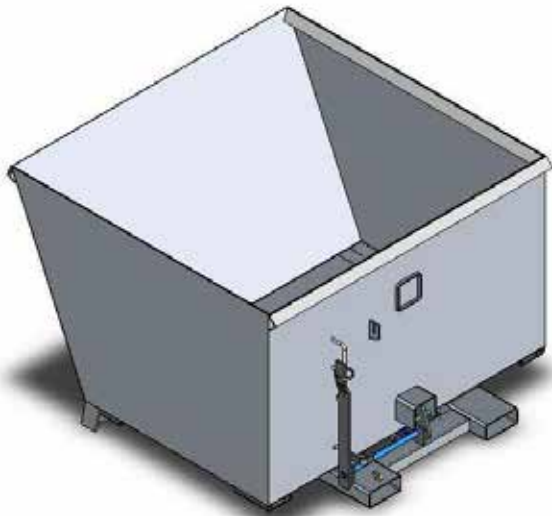

(Type NTU15 standard model shown)  
Refer 'NTU\_WL\_Sales' Product Specification sheet  
for Wheels & Crane Lug options.

The type NTU Heavy Duty Tip-Up Bin has been manufactured from 3mm plate and designed with fully reinforced edges. These Bins are ideally suited to heavy waste including metal, timber and building site rubble. The release mechanism is activated by the Forklift operator pulling the pull chord from the drivers seat. The custom built shock absorber prevents impact forces being transmitted to the Forklift during emptying.

All type NTU bins have a Safe Working Load of 1000kg and range in sizes from 0.7 – 2.0 cubic metre capacities. These bins are available in either enamel painted over primed steel or H.D. Galvanised finish.

### SPECIFICATIONS:

- Pocket size 165 x 65mm
- Pocket Centres – 635mm (NTU6 – 405mm)
- Safe Working Load 1000kg
- Unit Weight – refer Table
- Volume Capacity – refer Table
- HCG 800mm
- VCG 400mm
- Wheels, Crane Lugs & Lid Optional
- Drain Valve & Strainer Optional
- Hydraulic Option available

