

Type NCB Stackable Crane Bin

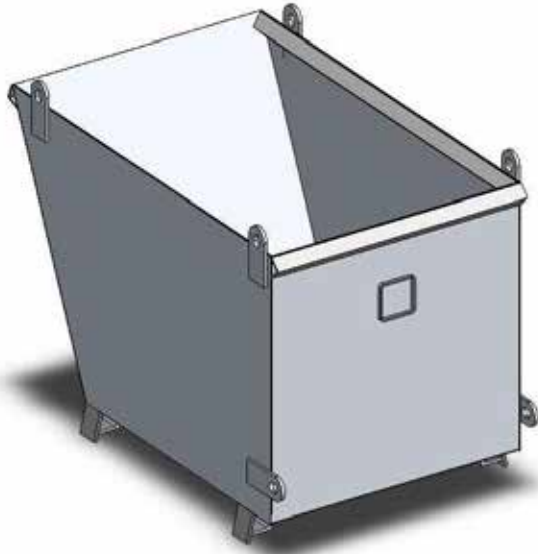

(Type NCB9 standard model shown)
Refer 'NCB_WS_Sales' product Specification sheet for Wheels & Fork Pocket options.

The type NCB Stackable Crane Bin has been designed for crane lifting and emptying. Stackable feet on the standard model allow easy handling by Forklift.

All type NCB bins have a Safe Working Load of 1000kg and range in size from 0.7 – 1.35 cubic metre capacities. These bins are available in either enamel painted over primed steel or H.D. Galvanised finish.

SPECIFICATIONS:

- Safe Working Load (SWL) 1000kg
- Unit Weight – refer Table
- Volume Capacity – Refer Table
- HCG – refer Table
- VCG 400mm

OPTIONS:

- Wheels, Lid, Fork Pockets
- Drain Valve & Strainer

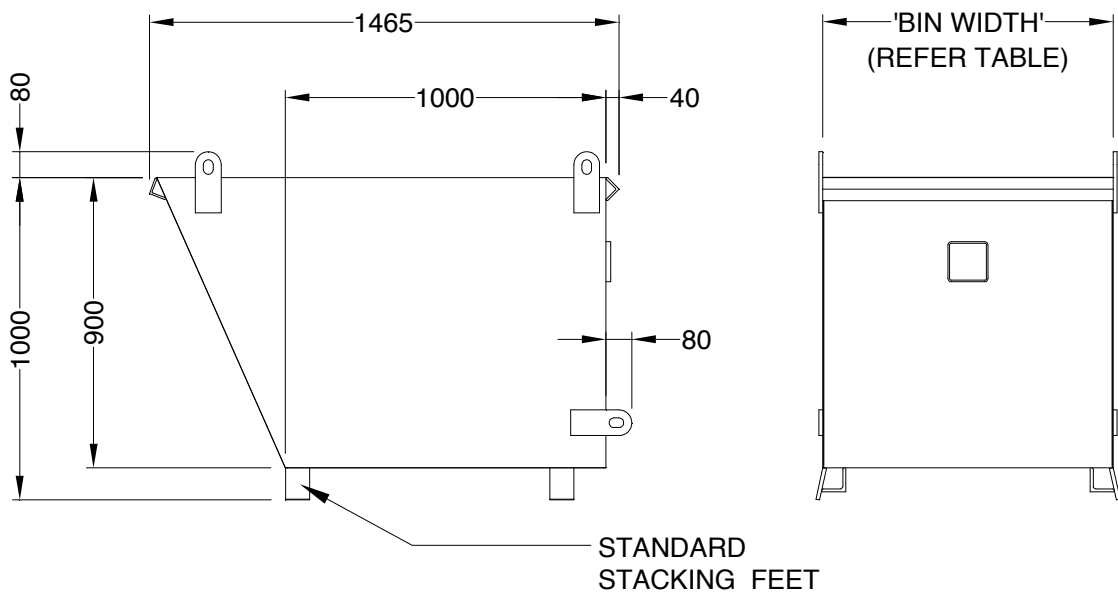

BIN TYPE	CAPACITY	'BIN WIDTH'	UNIT WEIGHT	H C of G
NCB-6	0.70 cu m	600mm	160kg	300mm
NCB-9	1.00 cu m	900mm	180kg	450mm
NCB-12	1.35 cu m	1200mm	190kg	600mm

Type NCB Stackable Crane Bin (Wheels & Fork Pocket Options)



The type NCB Stackable Crane Bin has been designed for crane lifting and emptying. Stackable feet on the standard model allow easy handling by Forklift.

All type NCB bins have a Safe Working Load of 1000kg and range in size from 0.7 – 1.35 cubic metre capacities. These bins are available in either enamel painted over primed steel or H.D. Galvanised finish.

SPECIFICATIONS:

- Safe Working Load (SWL) 1000kg
- Unit Weight – refer Table
- Volume Capacity – Refer Table
- HCG – refer Table
- VCG 400mm

OPTIONS:

- Wheels, Lid, Fork Pockets
- Drain Valve & Strainer

(Type NCB9 with optional Wheels & Fork Pockets shown)
Refer 'NCB_Sales' Product Specification sheet for the standard model configuration.

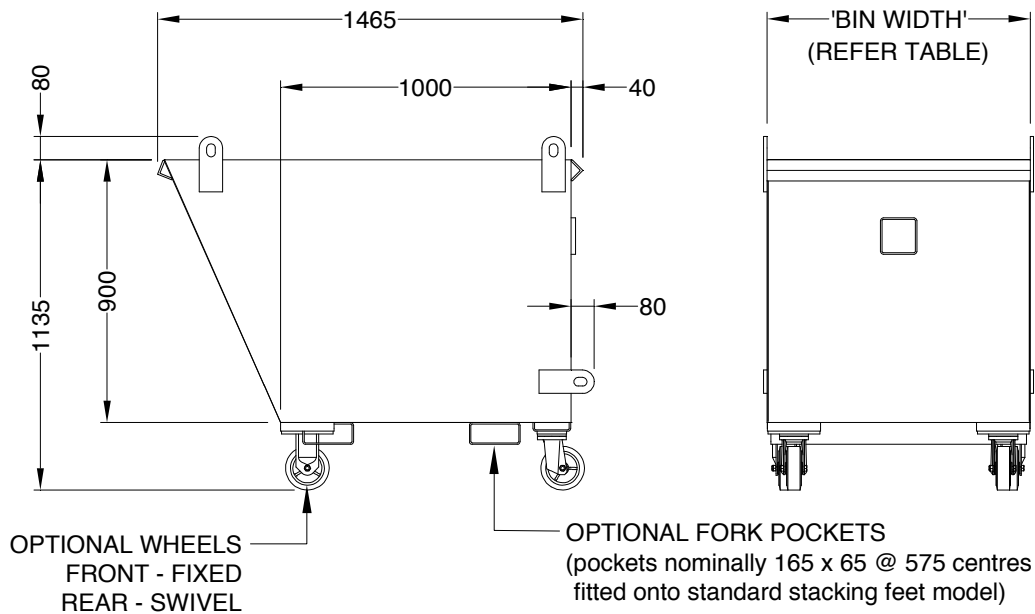

BIN TYPE	CAPACITY	'BIN WIDTH'	*UNIT WEIGHT	H C of G
NCB-6	0.70 cu m	600mm	180kg	300mm
NCB-9	1.00 cu m	900mm	200kg	450mm
NCB-12	1.35 cu m	1200mm	210kg	600mm

***NOTE: 'UNIT WEIGHT' includes Weight of WHEELS.**