

## Type CFS Fork Skip Bins

The light weight and cost effective type CFS Fork Skip Bins have been manufactured from 2mm plate and are suitable for goods or waste transport and storage. Fitted with a Forklift carriage and safety chain, two front wheels, a rear swivel wheel and push handle, these Bins are designed for **manual push over**.

The type CFS Fork Skip Bin is manufactured with a Zinc Plated finish as standard.

### SPECIFICATIONS:

- Pocket size 140 x 65mm
- CFS6 Pocket Centres – 367mm
- CFS9 Pocket Centres – 667mm
- Safe Working Load 350kg
- Unit Weight – refer Table
- Volume Capacity – refer Table
- HCG 350mm
- VCG 220mm
- Drain Plug fitted standard

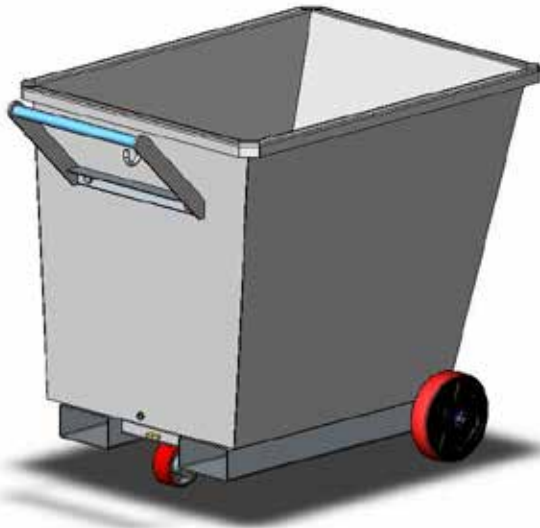

BIN TYPE	CAPACITY	WIDTH 'A'	WIDTH 'B'	UNIT WEIGHT
CFS 6	0.35cu m	730mm	718mm	65kg
CFS 9	0.50cu m	1030mm	1018mm	77kg

