

Type QHSHP-EXT Quick Hitch Single Hook Point (Extended) Jib

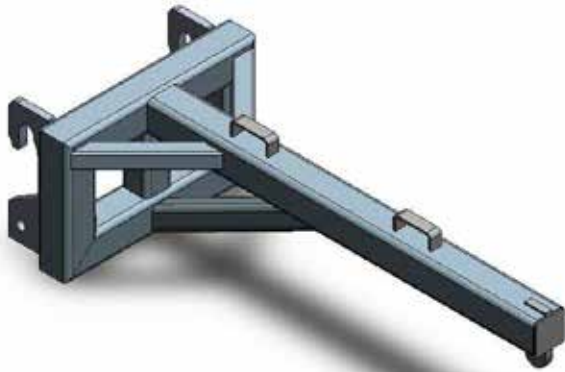

Quick Hitch (QH) Jib attachments are individually designed to attach to Industrial Truck carriages as specified by the Customer. The type QHSHP-EXT Quick Hitch Jib is an affordable Single Hook Point (Extended) Jib with a Safe Working Load (SWL) of 4000 kg.

All other specifications are dependent on the type of Quick Hitch carriage configuration the Jib is to be fitted to.

The standard finish on all Quick Hitch Jibs is painted 'Safety Yellow' enamel over primed steel.

SPECIFICATIONS:

- Safe Working Load (SWL) 4000kg
- Load Centre 2000mm approx.
- Unit Weight 250kg approx.

(Quick Hitch Plates – Customer specific)

