

## Type FJCS25 Fixed Jib (Short)

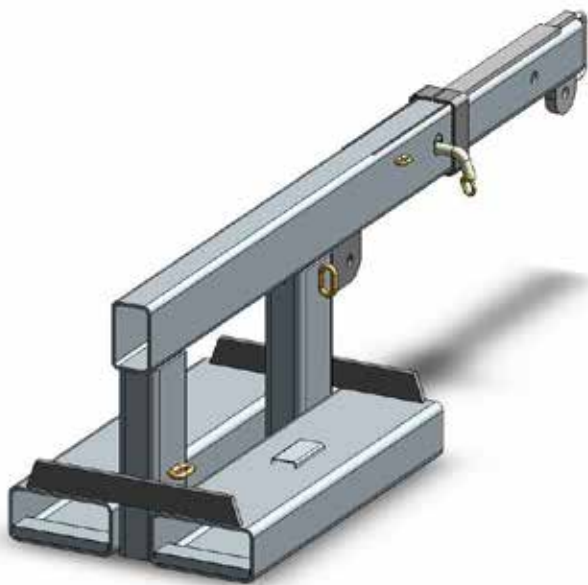

The type FJCS25 Fixed Jib (Short) is designed as an affordable general purpose Jib able to manoeuvre in confined spaces, with a 1.96 metre reach when fully extended. This slip-on Forklift attachment is held to the Forklift by a safety chain. The Jibs overall length when closed is 1.3 metres.

The standard finish on the type FJCS25 Fixed Jib (Short) is Zinc Plated.

### SPECIFICATIONS:

- Safe Working Load (SWL) 2500kg Max.
- Unit Weight 100kg
- Load Centre 790mm
- Pocket Size 185 x 65
- Pocket Centres 275 mm
- Horizontal C of G 630mm
- Vertical C of G 135mm

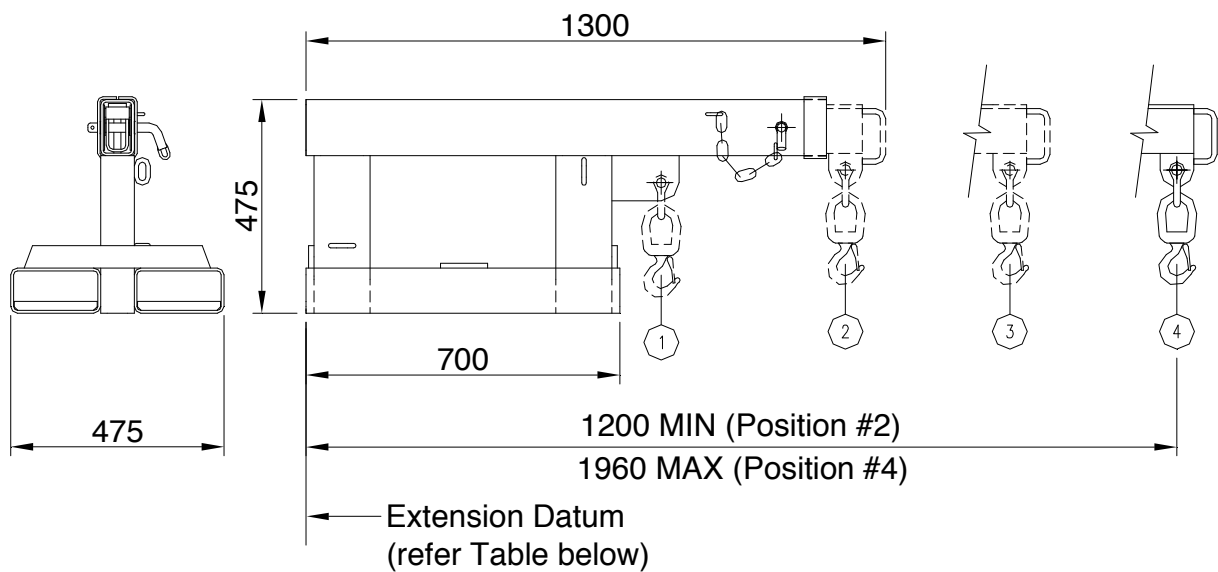

### SAFE WORKING LOADS (SWL) PER POSITION

POSITION	1	2	3	4
EXTENSION (mm)	790	1200	1580	1960
SWL (kg)	2500	1200	900	750

## Type FJCS45 Fixed Jib (Short)

The type FJCS45 Fixed Jib (Short) is designed as an affordable general purpose Jib able to manoeuvre in confined spaces, with a 1.925 metre reach when fully extended. This slip-on Forklift attachment is held to the Forklift by a safety chain. The Jibs overall length when closed is 1.255 metres.

The standard finish on the type FJCS45 Fixed Jib (Short) is Zinc Plated.



### SPECIFICATIONS:

- Safe Working Load (SWL) 4500kg Max.
- Unit Weight 95kg
- Load Centre 670mm
- Pocket Size 185 x 65
- Pocket Centres 290 mm
- Horizontal C of G 735mm
- Vertical C of G 120mm

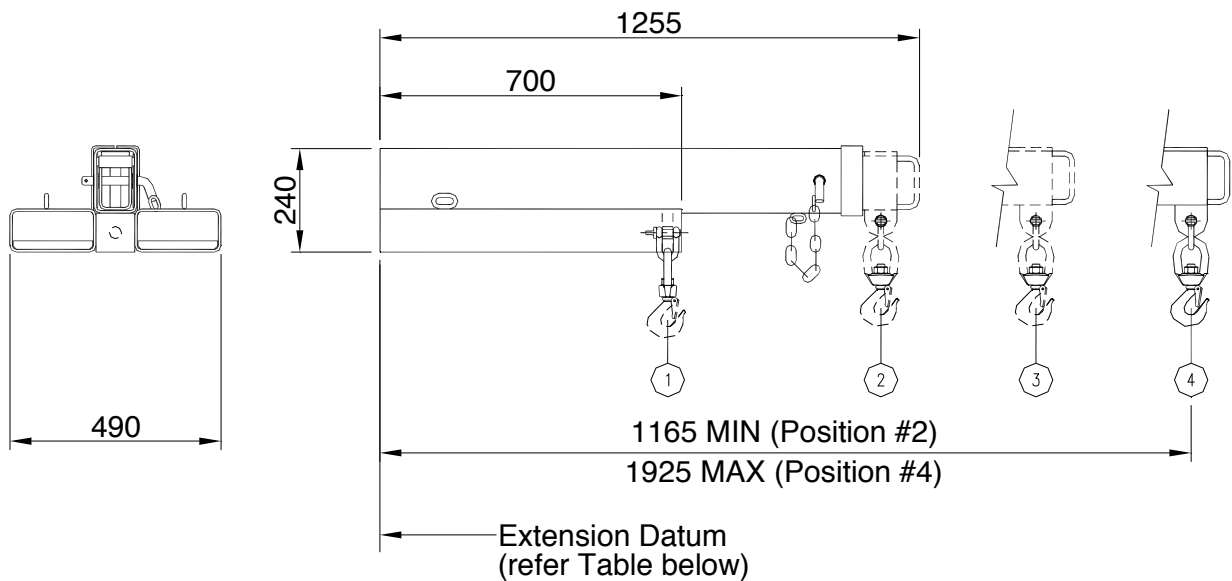

### SAFE WORKING LOADS (SWL) PER POSITION

POSITION	1	2	3	4
EXTENSION (mm)	670	1165	1545	1925
SWL (kg)	4500	2900	1300	750