

Type SW-NC Sideways Drum Rotator

The type SW-NC Sideways Drum Rotator is designed to lift and rotate 205 litre Drums through 360° perpendicular to the fork arms. A Hand Chain is used to rotate the Drum via a Gearbox for controlled rotation. A Chain Belly Strap with an eccentric lock holds the Drum firmly in position.

This slip-on attachment requires only the connection of a safety chain to a narrow carriage Forklift. The standard finish of this unit is painted enamel.

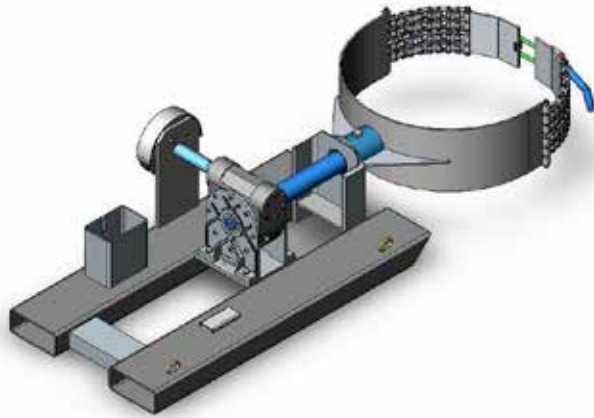

SPECIFICATIONS:

- Safe Working Load (SWL) 500kg
- Unit Weight 122kg
- 360° Rotation
- Load Centre 1385mm
- Pocket Size 165 x 65
- Pocket Centres 375mm
- Horizontal C of G 600mm

