

Type DR-NH Drum Rotator

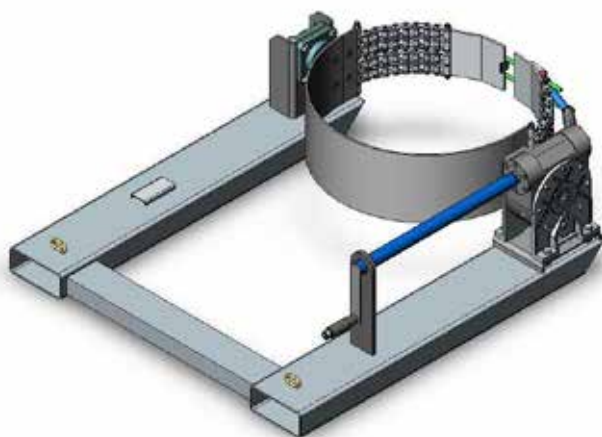

The type DR-NH Drum Rotator is designed to lift and rotate 205 litre Drums through 360°. Handle rotation via a Gearbox, of the drum cradle ensures minimum effort for fully controlled tipping, allowing complete emptying of the drum contents. A Chain Belly Strap with an eccentric lock holds the Drum firmly in position.

This slip-on attachment requires only the connection of a safety chain to the Forklift. The standard finish of this unit is Hot Dip galvanised.

SPECIFICATIONS:

- Safe Working Load (SWL) 500kg
- Unit Weight 100kg
- 360° Rotation
- Load Centre 930mm
- Pocket Size 165 x 65
- Pocket Centres 820mm
- Horizontal C of G 720mm

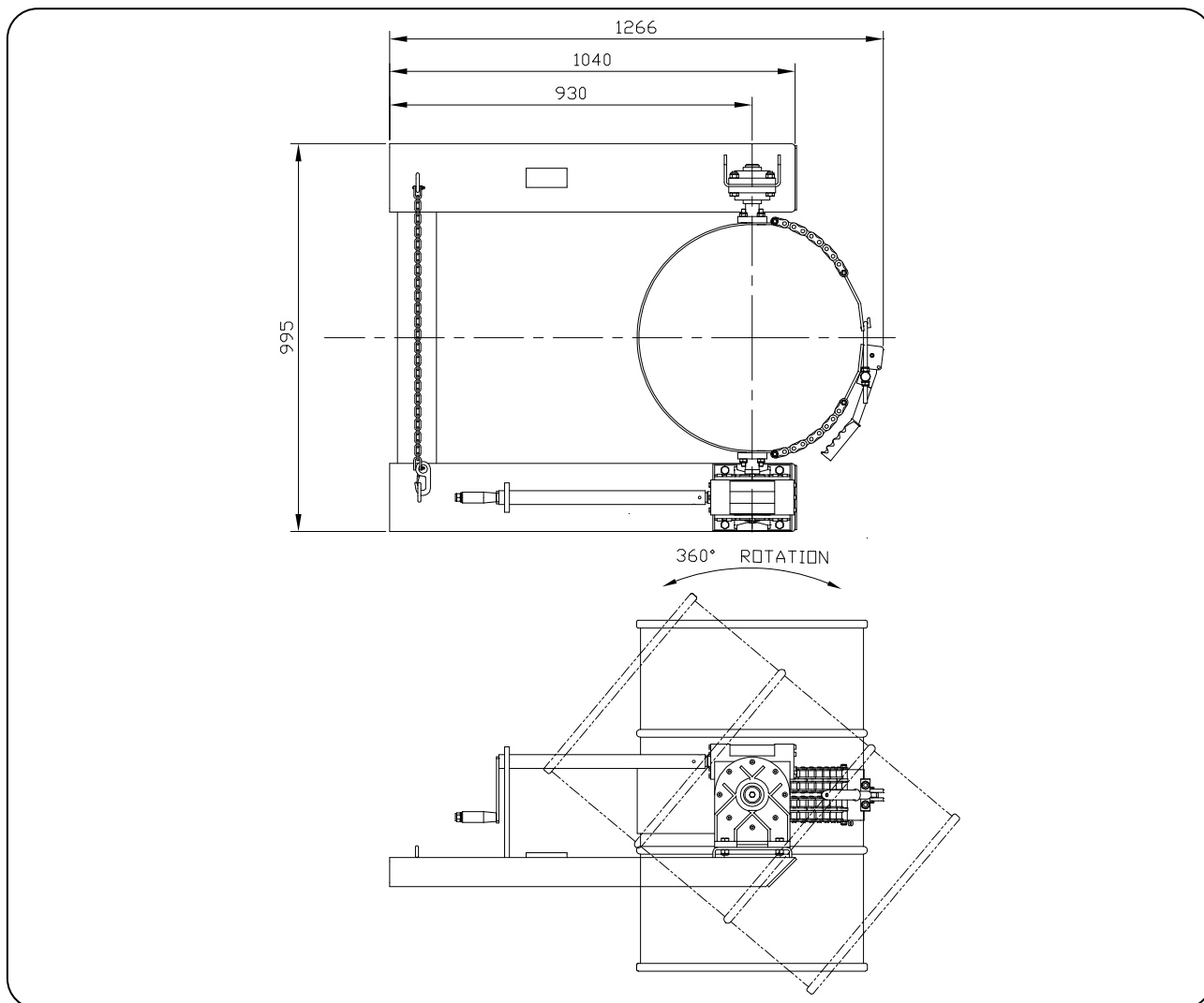

Type DR-NH Drum Rotator with PBO Option

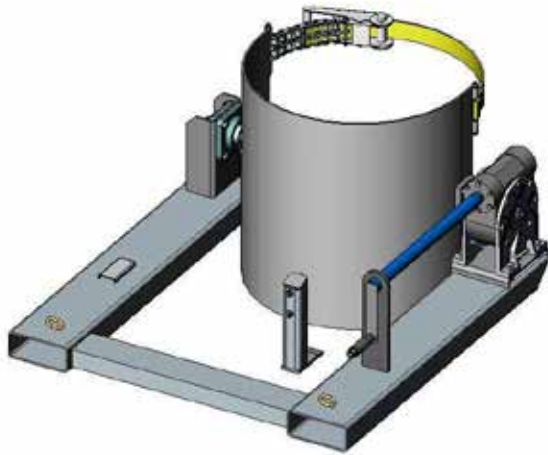

The type DR-NH Drum Rotator with the PBO Cradle fitted is designed to lift and rotate plastic Drums and Barrels as well as 205 litre steel Drums through 360°. Handle rotation of the PBO Cradle via a Gearbox, ensures minimum effort for fully controlled tipping, allowing complete emptying of the Drum/Barrel contents. The dual Woven/Chain combination Belly Straps holds the Drum/Barrel firmly in position.

This slip-on attachment requires only the connection of a safety chain to the Forklift. The standard finish of this unit is Hot Dip galvanised.

SPECIFICATIONS:

- Safe Working Load (SWL) 350kg
- Unit Weight 130kg
- 360° Rotation
- Load Centre 940mm
- Pocket Size 165 x 65
- Pocket Centres 820mm
- Horizontal C of G 720mm

