

Type FSNP2-3000 Carriage Mounted Fork Spreader



The type FSNP2-3000 Carriage Mounted Fork Spreader has been designed to safely lift extra wide or flexible loads without the risk of damage to products such as plasterboard, roof sheeting, timber or plastic tubing etc. Incorporating a loadguard, the Fork Spreader evenly distributes the load over its full length using Class 2 Fork Arms avoiding any product damage. This carriage mounted attachment is easily mounted to the Lift Truck and is able to be transported as a flat pack to be quickly assembled on site.

The standard finish on the type FSNP2-3000 Fork Spreader is enamel painted over primed steel.

SPECIFICATIONS:

- Carriage Mount – Class 2
- Total Width 3 Metres
- Fork Arms 125 x 35 x 1200mm long
- Safe Working Load 2000kg
- Load Centre 600mm
- Unit Weight 362kg
- Lost Load 100mm
- HCG 280mm
- VCG 205mm

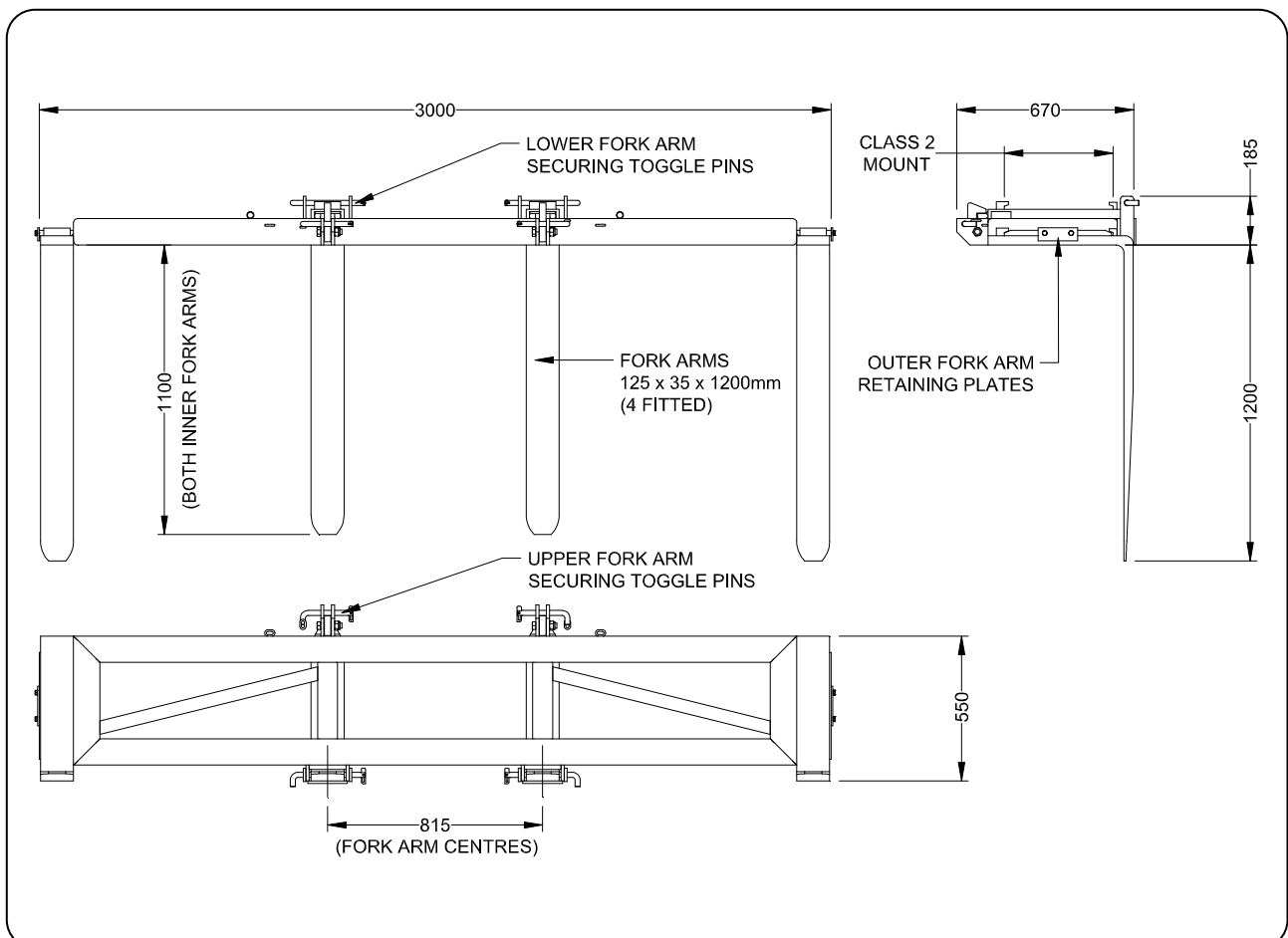

Type FSNP2-4500 Carriage Mounted Fork Spreader

The type FSNP2-4500 Carriage Mounted Fork Spreader has been designed to safely lift extra wide or flexible loads without the risk of damage to products such as plasterboard, roof sheeting, timber or plastic tubing etc. Incorporating a loadguard, the Fork Spreader evenly distributes the load over its full length using Class 2 Fork Arms avoiding any product damage. This carriage mounted attachment is easily mounted to the Lift Truck and is able to be transported as a flat pack to be quickly assembled on site.

The standard finish on the type FSNP2-4500 Fork Spreader is enamel painted over primed steel.

SPECIFICATIONS:

- Carriage Mount – Class 2
- Total Width 4.5 Metres
- Fork Arms 125 x 35 x 1200mm long
- Safe Working Load 2000kg
- Load Centre 600mm
- Unit Weight 425kg
- Lost Load 100mm
- HCG 230mm
- VCG 225mm

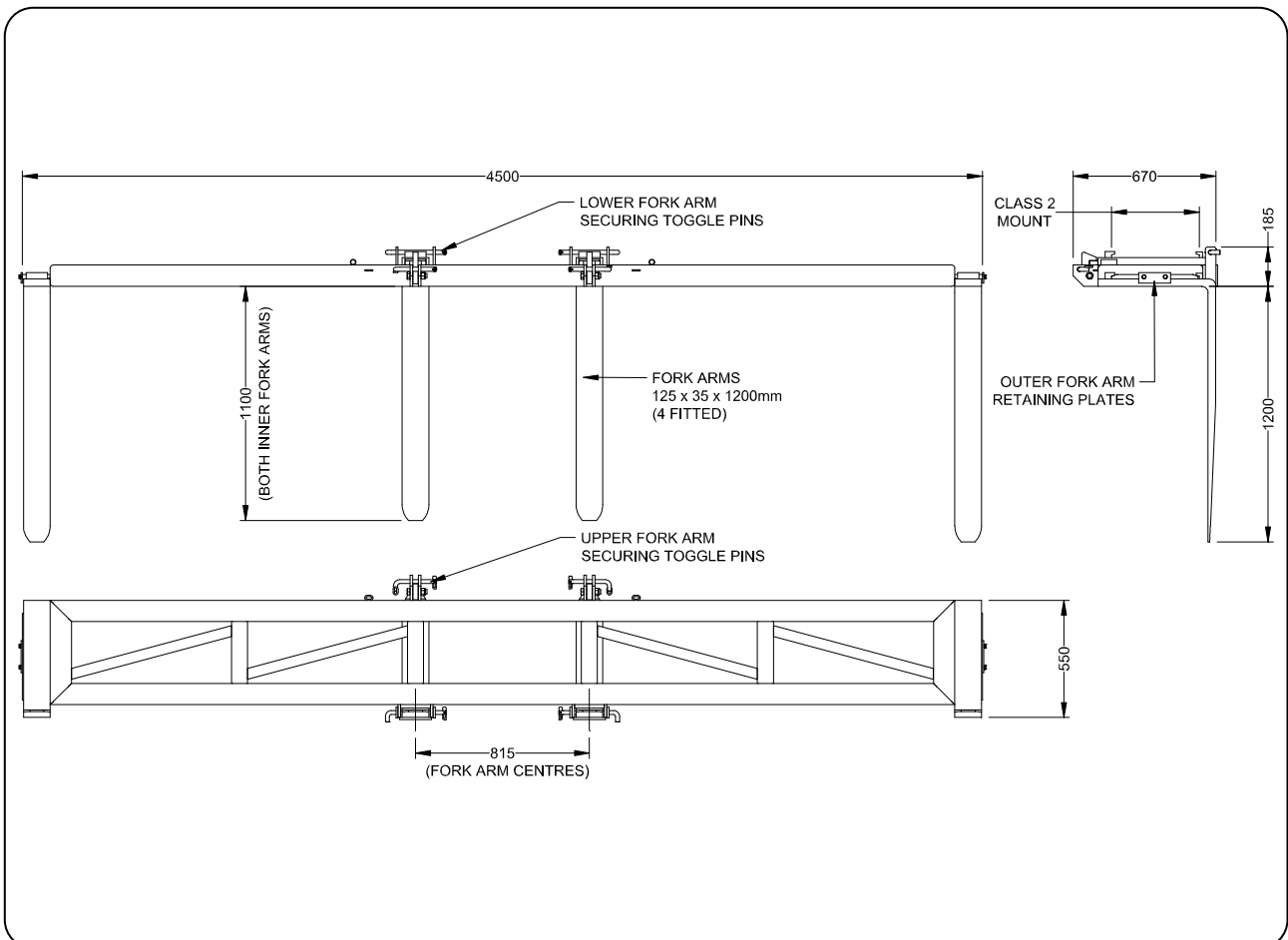

Type FSNP3-3000 Carriage Mounted Fork Spreader

The type FSNP3-3000 Carriage Mounted Fork Spreader has been designed to safely lift extra wide or flexible loads without the risk of damage to products such as plasterboard, roof sheeting, timber or plastic tubing etc. Incorporating a loadguard, the Fork Spreader evenly distributes the load over its full length using Class 3 Fork Arms avoiding any product damage. This carriage mounted attachment is easily mounted to the Lift Truck and is able to be transported as a flat pack to be quickly assembled on site.

The standard finish on the type FSNP3-3000 Fork Spreader is enamel painted over primed steel.

SPECIFICATIONS:

- Carriage Mount – Class 3
- Total Width 3 Metres
- Fork Arms 125 x 50 x 1200mm long
- Safe Working Load 4000kg
- Load Centre 600mm
- Unit Weight 525kg
- Lost Load 125mm
- HCG 272mm
- VCG 190mm

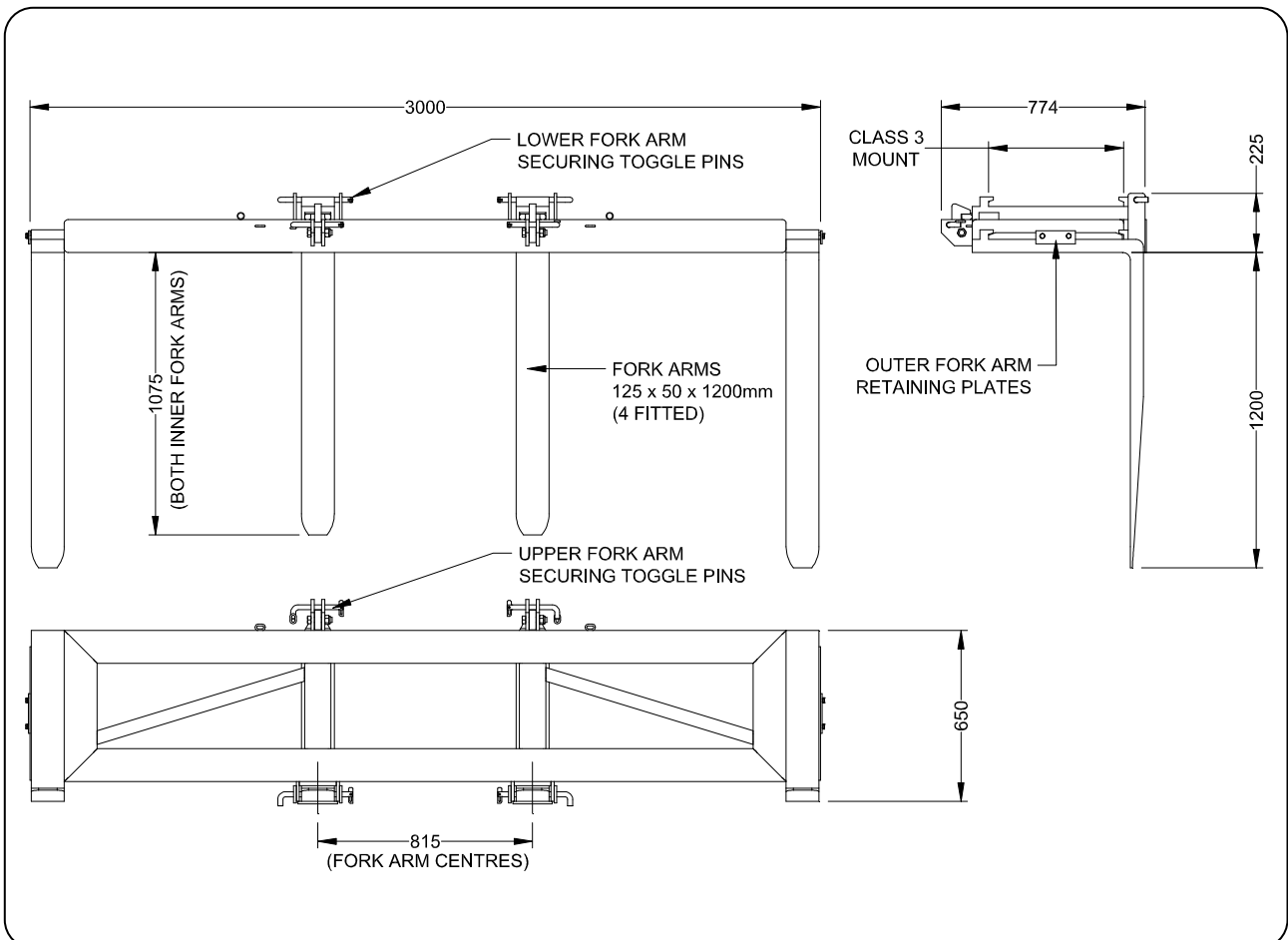

Type FSNP3-4500 Carriage Mounted Fork Spreader

The type FSNP3-4500 Carriage Mounted Fork Spreader has been designed to safely lift extra wide or flexible loads without the risk of damage to products such as plasterboard, roof sheeting, timber or plastic tubing etc. Incorporating a loadguard, the Fork Spreader evenly distributes the load over its full length using Class 3 Fork Arms avoiding any product damage. This carriage mounted attachment is easily mounted to the Lift Truck and is able to be transported as a flat pack to be quickly assembled on site.

The standard finish on the type FSNP3-4500 Fork Spreader is enamel painted over primed steel.

SPECIFICATIONS:

- Carriage Mount – Class 3
- Total Width 4.5 Metres
- Fork Arms 125 x 50 x 1200mm long
- Safe Working Load 4000kg
- Load Centre 600mm
- Unit Weight 605kg
- Lost Load 125mm
- HCG 250mm
- VCG 260mm

