

## Type FS2.5 Fork Spreader

The type FS2.5 Fork Spreader has been designed to safely lift extra wide or flexible loads without the risk of damage to products such as plasterboard, roof sheeting, timber or plastic tubing etc. The Fork Spreader evenly distributes the load over its full length. This slip-on attachment is easily fitted onto the Lift Truck fork tines and is secured by a safety chain.

Fork Spreaders may be designed and manufactured to suit your application on request. Please also refer to the type FS3-LG Fork Spreader & Load Guard Product Specifications.

The standard finish on the type FS2.5 Fork Spreader is enamel painted over primed steel.

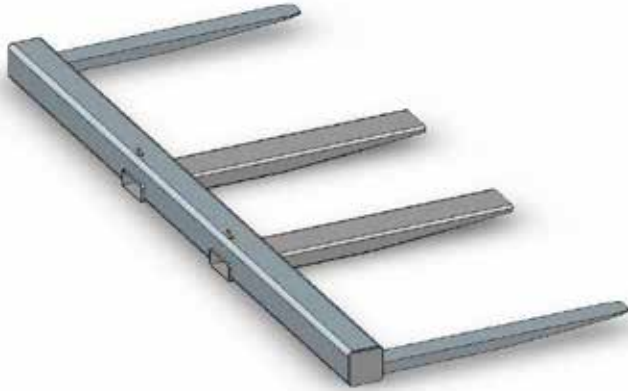

### SPECIFICATIONS:

- Pocket size 160 x 60mm
- Pocket Centres 775mm
- Safe Working Load 2500kg
- Load Centre 600mm
- Unit Weight 225kg
- HCG 320mm

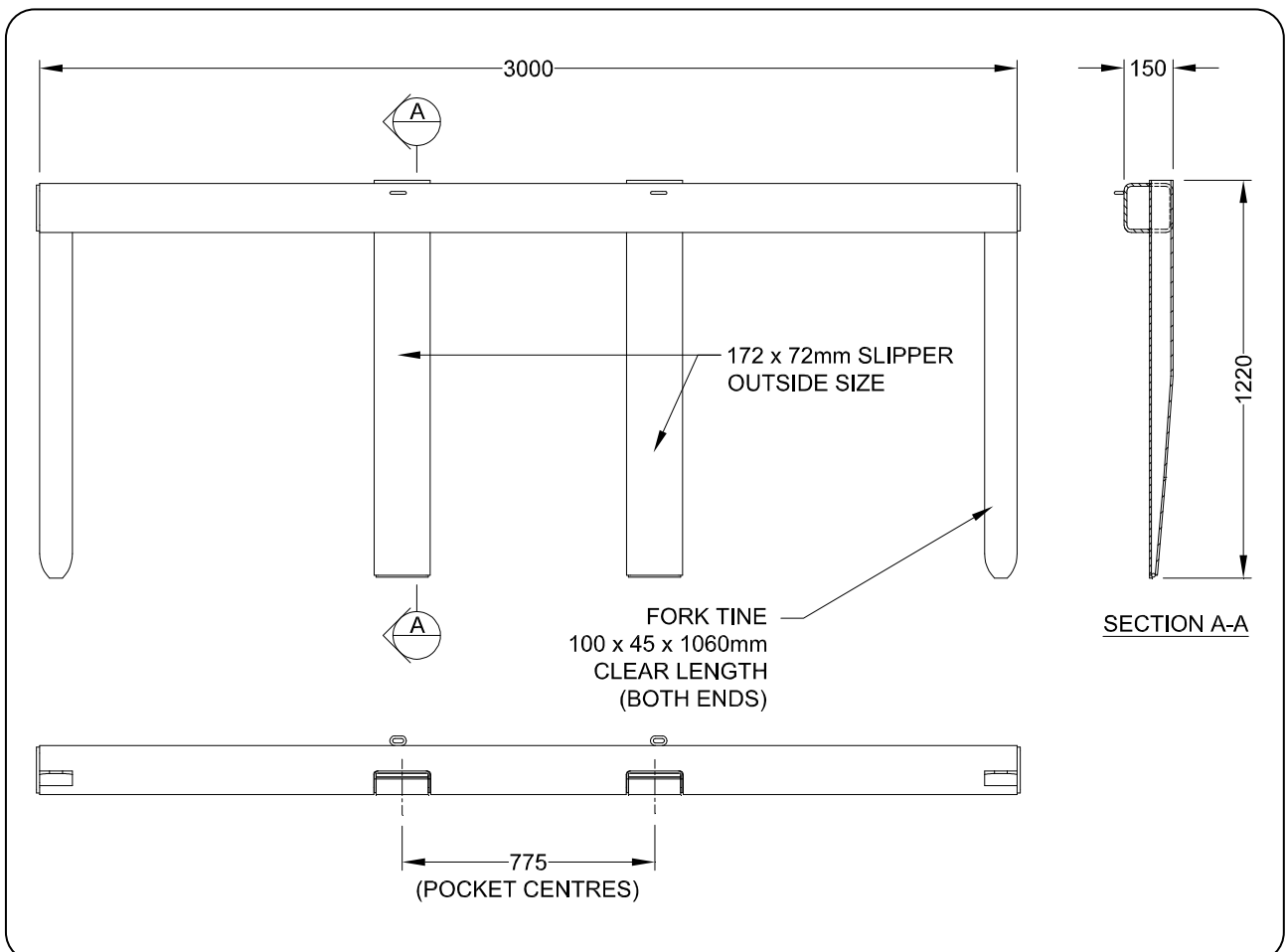

## Type FS3-LG Fork Spreader & Load Guard

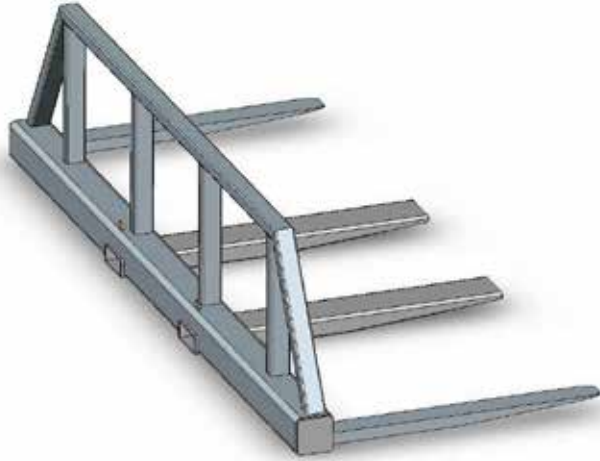

The type FS3-LG Fork Spreader & Load Guard has been designed to safely lift extra wide or flexible loads without the risk of damage to products such as plasterboard, roof sheeting, timber or plastic tubing etc. The Fork Spreader evenly distributes the load over its full length and has the extra benefit of a load guard incorporated into its design. This slip-on attachment is easily fitted onto the Lift Truck fork tines and is secured by a safety chain.

Fork Spreaders may be designed and manufactured to suit your application on request.

The standard finish on the type FS3-LG Fork Spreader & Load Guard is enamel painted over primed steel.

### SPECIFICATIONS:

- Pocket size 160 x 60mm
- Pocket Centres 775mm
- Safe Working Load 3000kg
- Load Centre 600mm
- Unit Weight 260kg
- HCG 300mm
- VCG 60mm

