

Type DBHS2 Hydraulic Dirt Bucket

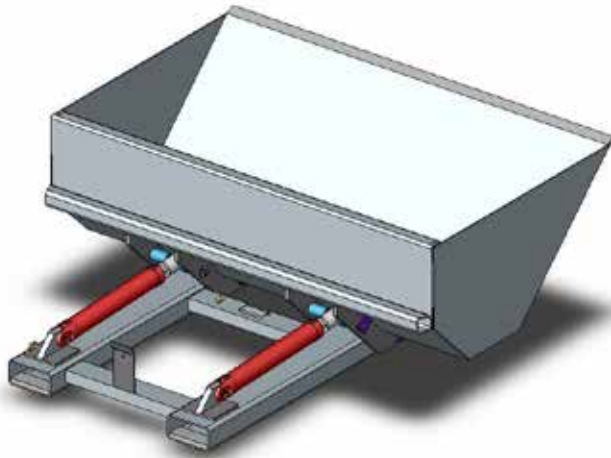

The type DBHS2 Hydraulic Dirt Bucket is a slip-on attachment allowing quick connection to a Forklift.

The hydraulic operation allows for full backwards tilt making the bucket suitable for liquid products. This bucket has been manufactured with a hardened steel wear edge.

The standard finish on the Dirt Bucket is Zinc Plated.

SPECIFICATIONS:

- Pocket size 185 x 65mm
- Pocket Centres 750mm
- Bucket Widths 1200mm & 1800mm
- Safe Working Load 1000kg
- For all other Specs. refer table below

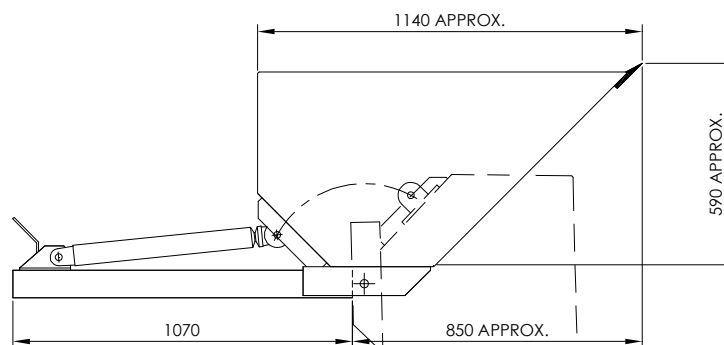
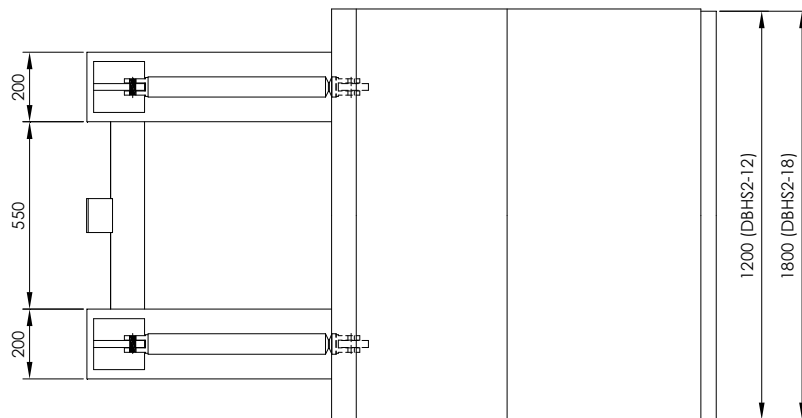

TYPE	DBHS2-12	DBHS2-18
POCKET SIZE	185 x 65	185 x 65
POCKET CTS	750mm	750mm
SWL	1000kg	1000kg
UNIT WEIGHT	315kg	390kg
HOR C of G	1050mm	1120mm
VERT C of G	165mm	140mm
CAPACITY	0.50 cu m	0.90 cu m