

Type CDR-500H Crane Drum Rotator

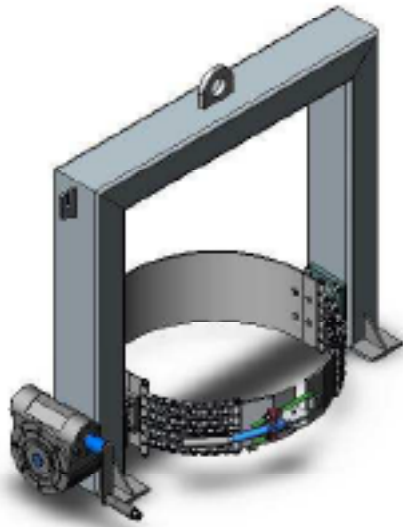

The type CDR-500H Crane Drum Rotator has been specifically designed for use by Crane. The Drum is quickly clamped into the holder via the twin Chain Belly Strap allowing 360° rotation.

This Unit is also available with a Chain driven gearbox for rotation – type CDR-500C.

SPECIFICATIONS:

- Safe Working Load (SWL) 500kg
- Unit Weight 120kg
- 360° Rotation
- Centus of Drum to Lifting Bys 790mm

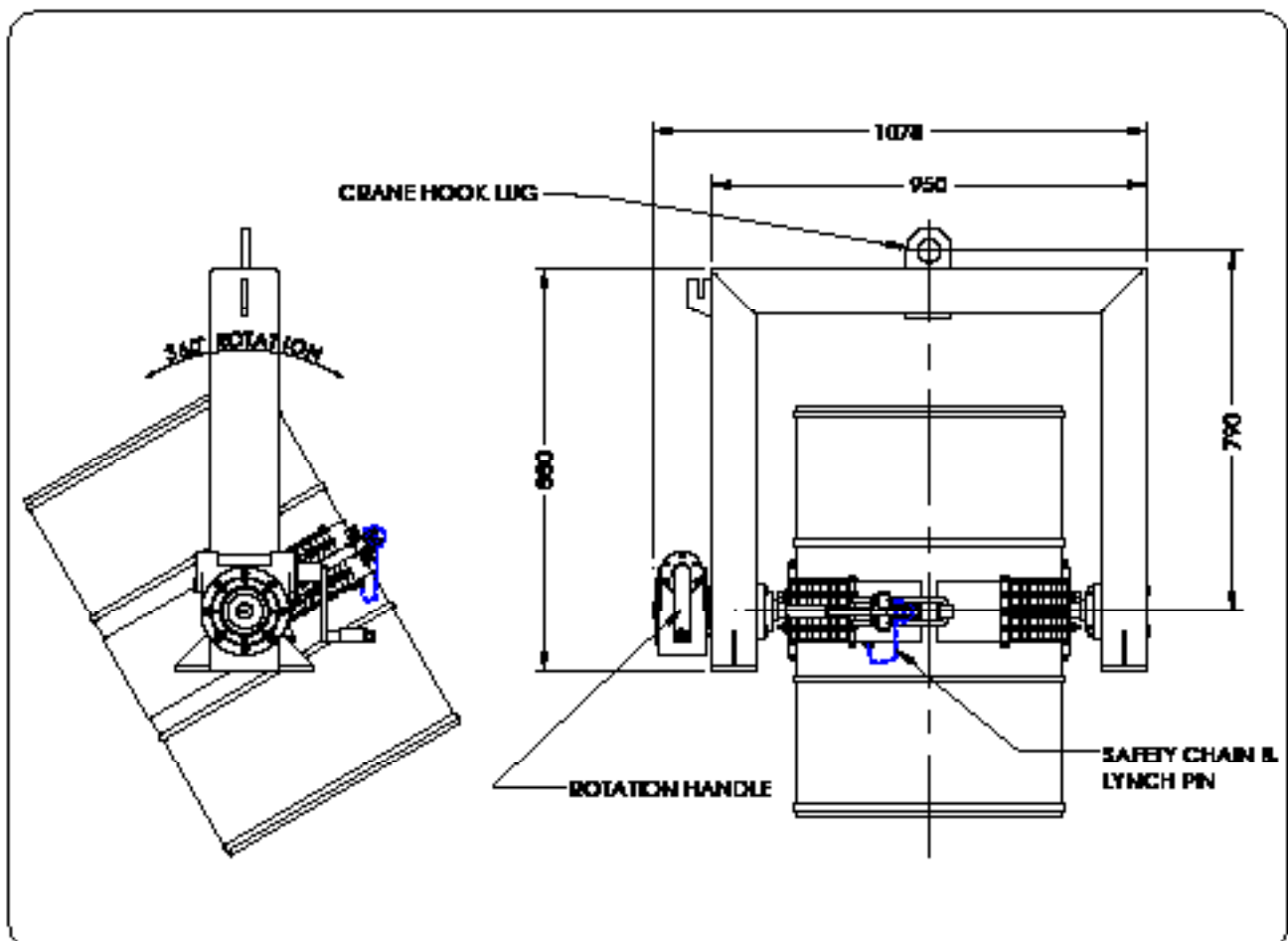

Type CDC-1 Crane Drum Clamp

The type CDC-1 Crane Drum Clamp uses a chain belly strap with ratchet tightening to allow clamping of standard 205 litre steel drums. This allows the drum to be transported about the workplace/site safely. The Unit is supplied with Lifting Chains.

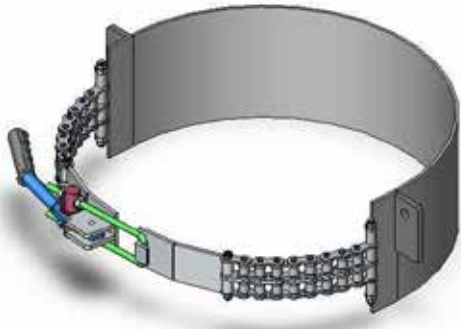

(shown without supplied Lifting Chains)

SPECIFICATIONS:

- Safe Working Load (SWL) 1000kg
- Unit Weight 30kg
- Chain Belly Strap with Over-centre Catch

