

## Type GK10-300 Grout Kibble

The GK10-300 Grout Kibble has been designed for bottom dumping of granular products, grout or equivalent materials.

The handle positioning and use of a 'Layflat' hose allows an unobstructed view by the operator of the material pour. The unit is designed with a Ø300 Butterfly Valve to allow the operator to control the pour via the handle. Forklift pockets have been provided for transport about the work site. The interior of the Kibble has a smooth surface allowing for easy discharge and quick cleaning.

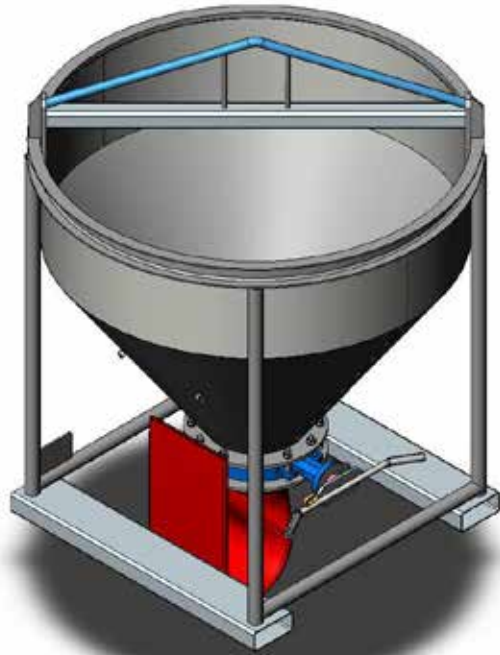

### SPECIFICATIONS:

- Safe Working Load (SWL) 3000kg
- Volume Capacity 1.0 cubic metres
- Unit Weight 285kg
- Fork Pocket Size 165 x 65mm
- Fork Pocket Centres 925mm
- Painted 'Safety Yellow' enamel

