

360° Hydraulic Rotators

Features:

- Continuous rotation in both directions
- Concealed drive motor protected from potential damage
- Designed to accept standard ISO fork arms
- Excellent driver visibility.

General Applications:

- Manufacturing
- Construction
- Food processing

Options:

- Various capacities available
- Quick Hitch adapters available
- Various mounting classes available
- Quick disconnect bottom hooks
- Fork positioning
- Reinforced tines suitable for 360° rotation

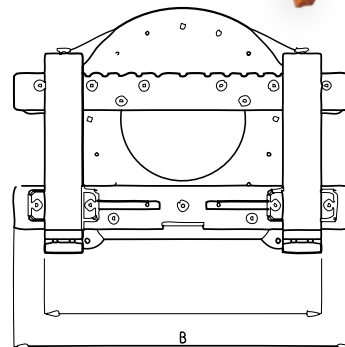
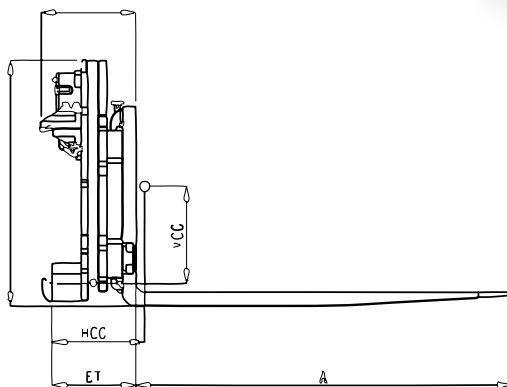
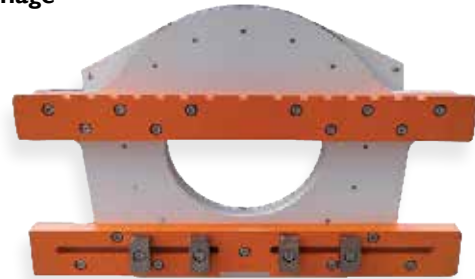

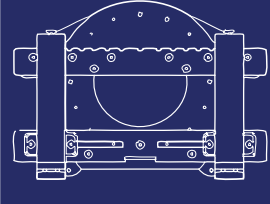
	Mounting Class	Capacity @Load Centre	Frame Width	Minimum Truck Carriage Width	Weight	Lost Load	Horizontal Centre of Gravity
Model		kg@mm	mm	mm	KG	mm	mm
XZQ20E-B002	II	2000/500	1115	800	311	160	88
XZQ30E-B001	II	3000/500	1100	800	378	228	145
XZQ30D-C001	III	3000/500	1100	800	378	228	145
XZQ45D-C001	III	4500/600	1200	1016	489	178	123
XZQ60E-D001	IV	6000/600	1200	1016	577	235	143