

Type HB1 Hopper Bin

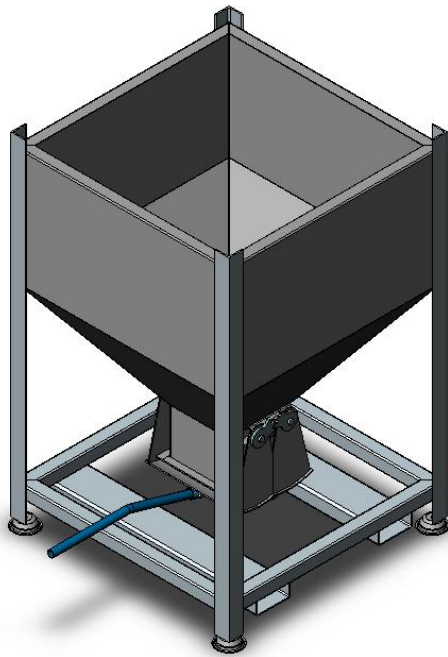

The type HB1 Hopper Bins have been designed with a unique “Clam Shell” opening mechanism and are available in three models with different volume capacities as detailed in the table below. The bin has been fitted with Forklift pockets and is stackable (2 high) in its standard configuration.

The standard finish of the type HB1 Hopper Bin is enamel painted over primed steel.

SPECIFICATIONS:

- Pocket size 160 x 65mm
- Pocket Centres – 625mm
- Safe Working Load 1000kg
- Unit Weight – refer Table
- Volume Capacity – refer Table
- HCG 600mm
- Crane Lugs & Wheels Optional
- Lid Optional

(Standard type HB1-10 model shown)

